



INSTRUCTIONS FOR USE

Read Instructions and Safety Precautions before use.

PRONEB[®] *Ultra*
COMPRESSOR NEBULIZER SYSTEM

PARI REUSABLE
INSIDE
NEBULIZER

TABLE OF CONTENTS

I.	Introduction	2
II.	Features and Functions	2
III.	Safety Precautions.....	2
IV.	Getting Started.....	4
V.	Set-up.....	4
VI.	Specifications	5
VII.	Maintenance Of The PRONEB® ULTRA.....	5
VIII.	PRONEB® ULTRA Limited Warranty	6
IX.	Repair Return Procedure	7

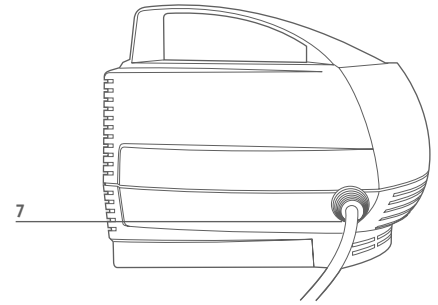
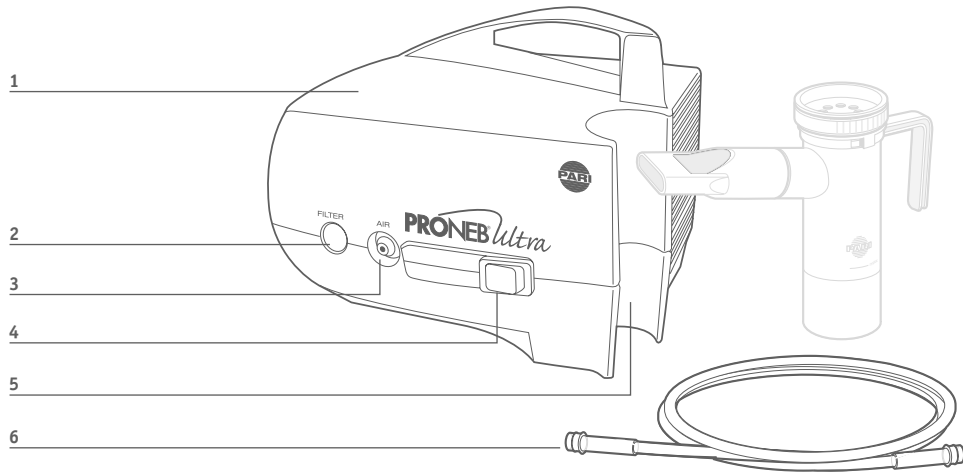

FIG. A

FIG. B

FIG. C

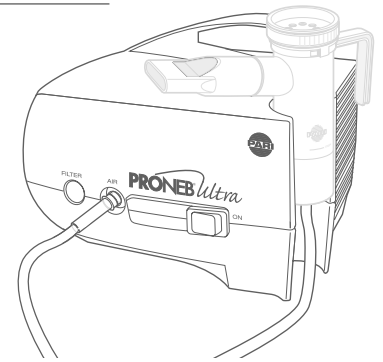
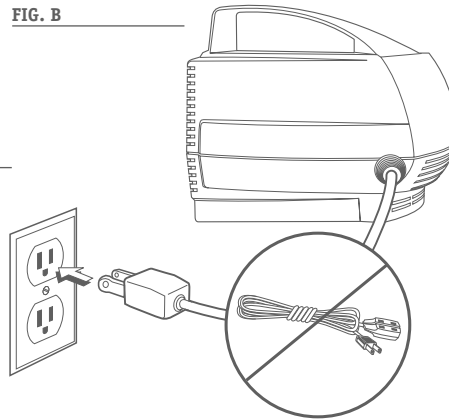
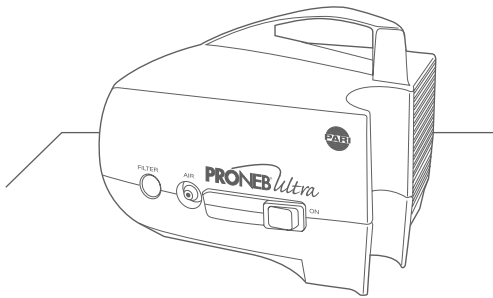
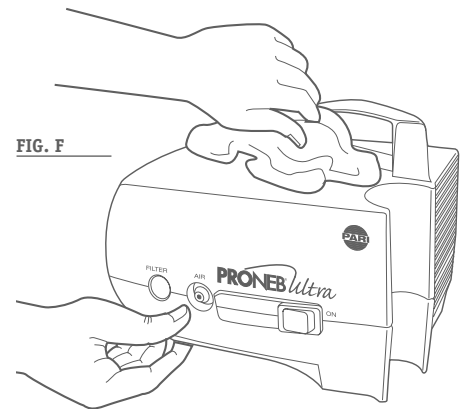
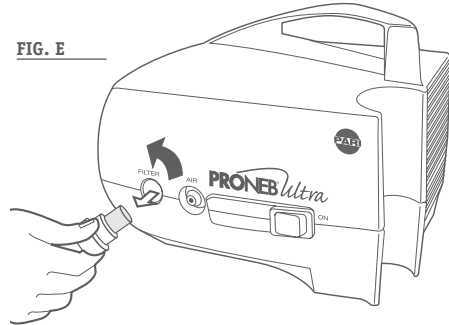
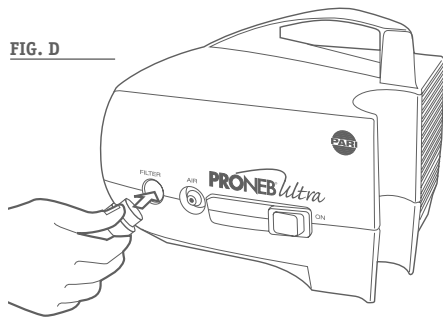

FIG. D

FIG. E

FIG. F



I. Introduction

These Instructions For Use contain Information and Safety Precautions on the **PRONEB[®] ULTRA** Compressor System. Open the inside front cover to view illustrations for setup of your **PRONEB[®] ULTRA**. The illustrations will be referenced throughout these Instructions For Use. Separate Instructions For Use are included with the enclosed PARI Reusable Nebulizer.

Before using your **PRONEB[®] ULTRA**, you should read and understand the entire Instructions For Use for both the **PRONEB[®] ULTRA** and the PARI Reusable Nebulizer. Take special note of all safety precautions marked DANGER and WARNING. Save these Instructions For Use for future reference.

II. Features And Functions (see illustrations)

1. **PRONEB[®] ULTRA** Compressor
2. Clear View™ Air Filter
3. Air Outlet
4. On/Off Switc
5. Reusable Nebulizer Holder
6. Tubing
7. Power Cord

III. Safety Precautions

IMPORTANT SAFEGUARDS

READ ALL INSTRUCTIONS BEFORE USING.

WARNING

U.S. Federal Law restricts this device to sale by or on the order of a physician. Use only when prescribed by a physician and with the prescribed medication.

Read all warnings and instructions before use. Use the product only for its intended use as described in these Instructions For Use. Improper use can result in serious or fatal illness/injury, improper treatment or property damage.

Use only with nebulizers and tubing authorized by PARI for this device. Other nebulizers and tubing may result in improper treatment.

When using electrical and medical products, especially when children are present, basic safety precautions should always be followed, including the following:

⚠ DANGER

To reduce the risk of serious or fatal injury from electrocution:

1. Do not place or store product where it can fall or be pulled into a bathtub, sink, water, or other liquid. Do not place in or drop into water or other liquid. Do not use while bathing.
2. Do not reach for a product that has fallen into water or other liquid. Unplug immediately.
3. Always unplug this product immediately after using.

⚠ WARNING

To reduce the risk of serious or fatal injury from electrocution, fire or burns and to reduce the risk of damage and malfunction to the unit:

1. Before use, check the serial number label on the bottom of the **PRONEB**• ULTRA Compressor to ensure that the voltage and current indicated on the unit correspond to the voltage and current available.
2. Never operate this product if it has a damaged cord or plug, if it is not working properly, if it has been dropped or damaged, or if it has been exposed to any liquids inside the case. Return the product to an authorized PARI Service Center for examination and repair.
3. Keep all electrical cords away from heated surfaces. Do not overload wall outlets or use extension cords.
4. This appliance has a polarized plug (one blade is wider than the other). As a safety feature, this plug will fit in a polarized outlet only one way. If the plug

does not fit fully in the outlet, reverse the plug. If it still does not fit, contact a qualified electrician. Do not attempt to defeat this safety feature.

5. Never block the air vents of this product or place it on a soft surface, such as a bed or couch, where the air vents may be blocked. Keep the air vents free of lint, hair, and similar substances. Blockage could cause excessive heat buildup. A product should never be left unattended when plugged in.
6. Do not operate outdoors.
7. Do not operate where oxygen is being administered in a closed environment such as an oxygen tent.
8. Never drop or insert any object into any openings.
9. Be sure the **PRONEB**• ULTRA is unplugged prior to cleaning.
10. Do not open or disassemble the **PRONEB**• ULTRA Compressor. Refer all servicing to an authorized PARI Service Center.

⚠ WARNING

Close supervision is necessary when this product is used by or near the physically or mentally impaired or children. Never use while sleeping or drowsy. This product contains small parts that may present a choking hazard to small children. The tubing also presents strangulation hazard. Always use close adult supervision when administering a treatment to a child. **DO NOT LEAVE CHILD UNATTENDED DURING TREATMENTS.**

SAVE THESE INSTRUCTIONS

IV. Getting Started

1. Check the **PRONEB**• ULTRA packing box and make sure the following basic components are included:

PRONEB• ULTRA Compressor

Clear View™ Air Filter (in compressor) (reorder #85F0012)

PRONEB• ULTRA Instructions For Use with warranty card

PARI Reusable Nebulizer Set with Instructions For Use

If you did not receive the components listed, please contact the dealer where you purchased your **PRONEB**• ULTRA. Some models may include additional accessories such as a video, carrying case, etc.

2. Fill out the warranty card completely and mail.
3. It is a good idea to always keep an extra PARI Reusable Nebulizer and extra compressor air filter on hand at all times. You may need it if parts become lost or damaged.

V. Set-Up

1. Place the **PRONEB**• ULTRA on a stable, flat surface. Do not place on cushioned, upholstered, or carpeted surfaces. Place the unit in an area that is clean and free of dust (Fig. A).
2. The Clear View™ Filter in the front of the compressor allows you to check the condition of the filter at any time without removing it. When the compressor is new, note the bright white color of the filter. There is no reason to remove the filter at any time until you are ready to replace it. Details regarding when to replace the filter are covered under “Maintenance” on page 5.
3. Connect the polarized plug on the power cord to a polarized wall outlet (Fig. B). Do not use an extension cord.
4. Open the nebulizer package and read and follow the nebulizer’s Instructions For Use.
5. It is important to firmly push the tubing all the way onto the air outlet of the compressor prior to starting the treatment (Fig. C). The tubing is designed to fit tightly.

6. Patients who use a 2.5 ml volume fill will generally find that the **PRONEB**[®] ULTRA will deliver the treatment in less than 10 minutes. Treatment time is always a variable based on the patient's age and condition. The **PRONEB**[®] ULTRA was designed for intermittent use to deliver respiratory medications, not continuous use for humidification or prolonged treatments (over 35 minutes at one time). It is possible that with prolonged treatments the tubing may get warm and disconnect from the **PRONEB**[®] ULTRA. If you are a patient and will be using the **PRONEB**[®] ULTRA for back to back treatments that are longer than 35 minutes combined, please contact PARI Patient Connection at 1.877.943.3931, then press 1 for tips on prolonged treatments.

Note: Your **PRONEB**[®] ULTRA Compressor has a nebulizer holder on the front of the unit (Fig. C). This nebulizer holder allows the nebulizer to be placed in the front of the **PRONEB**[®] ULTRA with the tubing attached.

VI. Specifications

Compressor Specifications:

Weight:4.0 lb.
 Dimensions:5.75 x 7.5 x 5.5 in.
 Electrical Requirements:120V AC, 60Hz, 1.6A
 Power Wattage:98 W, under normal load
 Ambient Operating
 Temperature Range:10°C to 40°C, (50°F to 104°F)

Transport/Storage Range:

Ambient temperature:-40°C to 70°C, (-40°F to 158°F)

Relative Humidity:10% to 100%, including condensation

Atmospheric Pressure:500 hpa to 1060 hpa

Explanation Of Symbols:

ON/OFF 

VII. Maintenance Of The PRONEB[®] ULTRA

Tubing Maintenance

If there is any moisture or condensation in the tubing after the treatment, let the compressor run with only the tubing attached for a few minutes. The warm air from the compressor will dry the moisture or condensation in the tubing. Use a damp cloth to wipe the exterior of the tubing.

Filter

The Clear View™ Filter on the front of the **PRONEB**[®] ULTRA Compressor was designed to be monitored without removing it. This makes it easy to check without much work. When the filter is new, it is bright white in color. Over time, the filter will turn grey, which means it is time to replace it. You must also replace the filter if it gets wet or becomes clogged. There is no reason to remove the filter until you are ready to replace it. The filter is rated to last 500 hours of use before replacement is required. A good general rule is to replace the filter whenever you replace your PARI Reusable Nebulizer.

For filter replacement, obtain the replacement filter set part #85F0012 which includes the filter and the filter removal tool (Fig. D). Push the filter tool firmly over the filter and rotate the filter removal tool counter clockwise a **full 8 turns** until loose and pull the filter out (Figs. D and E). Discard the dirty filter and tool. The filter tool prevents unwanted removal of the filter or a lost filter.

Once the filter is removed, tilt the compressor so that the face of the unit is facing the floor. Gently tap on the back of the compressor to remove any unwanted materials from the filter area. Place the compressor on a stable surface and using clean hands, push a new filter into the filter receptacle.

Note: Do not attempt to wash and reuse filters. Do not use substitute filter material. Compressor damage may result.

Cleaning the PRONEB• ULTRA Housing and Tubing

Use a damp cloth to wipe the exterior of the **PRONEB• ULTRA** housing and tubing (Fig. F).

▲ WARNING

Never spray fluid into the ventilation slots on the **PRONEB• ULTRA** Compressor. Fluid could cause damage to the electrical and compressor parts and could lead to a malfunction. In the event that fluid enters the unit, return the product to an authorized PARI Service Center for examination and repair.

MAINTENANCE AND REPAIR

Never operate the **PRONEB• ULTRA** if it is improperly or incompletely assembled, or damaged. Use only original PARI parts and attachments authorized by PARI Service Center for the **PRONEB• ULTRA**. Use of other parts and attachments may damage the unit or cause improper treatment. Do not open or disassemble the compressor unit at any time. Repairs, service and maintenance should be carried out only by an authorized PARI Service Center.

Note: There are no user serviceable parts inside the **PRONEB• ULTRA** Compressor case. Service by anyone other than an authorized PARI Service Center voids warranty.

VIII. PRONEB• ULTRA Limited Warranty

PARI offers a standard limited three (3) year warranty or an extended five (5) year warranty on the **PRONEB• ULTRA** Compressor and its parts. The warranty period is determined by which model is purchased. The warranty period will be printed on the serial number label located on the bottom of the compressor.

PARI warrants that the **PRONEB• ULTRA** Compressor and its parts will be free from defects in workmanship and materials for a period of thirty-six (36) months or sixty (60) months, depending on the model, from the date of first retail purchase of the equipment. This warranty does not cover failures of the nebulizer, tubing, or accessories. This warranty does

not extend to failures resulting from accident, misuse, abuse, alteration, use of unauthorized service; parts or cleaning solutions, or failure to comply with Instructions For Use.

If the warranted equipment should fail during the warranty period, PARI, at its option, will repair or replace the equipment or parts at issue, provided the claim is bona fide. It shall be the responsibility of the purchaser to pack and return the equipment in a manner to avoid shipping damage. The shipment must be prepaid to PARI Respiratory Equipment, Inc. This warranty covers the cost of labor incurred in the removal or replacement of the warranted component parts at authorized PARI service centers only. To make a claim under this warranty, notify the authorized service center by calling PARI Patient Connection at:

1.877.943.3931, Press 1

THERE ARE NO OTHER EXPRESS WARRANTIES. ALL IMPLIED WARRANTIES ON THE **PRONEB*** ULTRA AND ITS PARTS, INCLUDING IMPLIED WARRANTIES OF MERCHANTABILITY AND FITNESS FOR A PARTICULAR PURPOSE, ARE LIMITED TO THIRTY-SIX (36) MONTHS OR SIXTY (60) MONTHS FROM THE DATE OF FIRST RETAIL PURCHASE. ALL EXPRESS OR IMPLIED WARRANTIES ON ANY OTHER PARTS, INCLUDING THE IMPLIED WARRANTIES OF MERCHANTABILITY AND FITNESS FOR A PARTICULAR PURPOSE, ARE DISCLAIMED. Some states do not allow limitations on how long an implied warranty lasts, so the above limitation may not apply to you.

The sole and exclusive remedy under this warranty is to repair or replace the **PRONEB*** ULTRA and/or its parts at the option of PARI. IN NO EVENT SHALL PARI BE LIABLE FOR INCIDENTAL OR CONSEQUENTIAL DAMAGES TO THE PURCHASER OR ANY THIRD PARTY, INCLUDING WITHOUT LIMITATION, DAMAGES ARISING FROM LOST PROFITS, LOSS OF BUSINESS OPPORTUNITY, LOSS OF PROPERTY, ECONOMIC LOSSES, OR STATUTORY OR EXEMPLARY DAMAGES, WHETHER IN NEGLIGENCE, WARRANTY, STRICT LIABILITY OR OTHERWISE. Some states do not allow the exclusion or limitation of incidental or consequential damages, so the above limitations or exclusions may not apply to you.

This warranty gives you specific rights. You may also have other rights which vary from State to State.

IX. Repair Return Procedure

1. Contact PARI Patient Connection at 1.877.943.3931, Press 1 for an authorized service center.
2. In writing, describe the malfunction or symptoms of the **PRONEB*** ULTRA. Include your full name, address and daytime telephone number.
3. Send written description and **PRONEB*** ULTRA in a protective box to the address provided by Patient Connection.



PARI RESPIRATORY EQUIPMENT, INC.
3 Justin Court, Monterey, California 93940
Tel 831.658.0901 Fax 1.800.727.4112
USA AND CANADA 1.800.FAST.NEB (327.8632)

PARI.COM

E-mail ProductInfo@PARI.com
Respiratory CEU programs available
© 2001 PARI RESPIRATORY EQUIPMENT, INC.

